

INSTALLATION INSTRUCTIONS TCHDRND1

FITS BOTH LEFT-HAND OR RIGHT-HAND HINGED GATES

Some important points concerning the installation of 'ROUND-POST HINGES':

- Note that each hinge has five different-sized adaptors to fit various diameters of posts or gate frames.
- The adaptors in this pack fit the following diameters:
GATES (to fit the small side of the hinge): 1³/₈" , 1⁵/₈" (35 & 41mm)
POSTS (to fit the large side of the hinge): 1⁷/₈" and 2" , 2³/₈" , 2⁷/₈" (48-51, 60 & 73mm)
- Wherever possible, keep the "adjustable end" of the hinge (indicated by screw endcap) facing up for ease of tension adjustment.
- The hinges should be installed as far apart vertically as is practical.

Tools required: Electric drill/cordless drill, ³/₁₆" (4.8mm) & ⁵/₃₂" (4mm) drill bits, Phillips No. 2 screwdriver (hand & power), ⁵/₁₆" hex-head driver and large slot-head screwdriver.

PROCEDURE

In preparation for installation of the hinges, choose the appropriate round-post adaptors by placing them onto the post to determine the correct fit. Each adaptor should fit neatly around the diameter of the gate and the post. Discard unwanted adaptors.

1. Insert the adaptors for the gate frame into the rear of the hinges, ensuring the location 'lugs' at the rear of the adaptors fit snugly into the hinges.
2. Take the hinges and align/position them onto the gate to suit the style of latch used (see Diagrams A & B).
3. Take the hex-shaped screws (12g-24x25mm) and secure the hinges to the gate. A pilot hole of ³/₁₆" (4.8mm) will be required. Note the need for hinge vertical alignment (level), as shown in Diagram C. The wafer-head screws (10g-24x22mm) for the side-fixing legs are to be installed once the gate is hung.
4. Insert the post adaptors into the rear of the hinges.
5. Take the gate and locate it into the desired position/height. You may need to prop up and support the gate temporarily during installation.
6. Ensuring the gate is correctly aligned with the fence (see Diagrams A & B), take the remaining hex-head screws and secure the hinges (the gate) to the post. Again, pilot hole of ³/₁₆" (4.8mm) will be required.

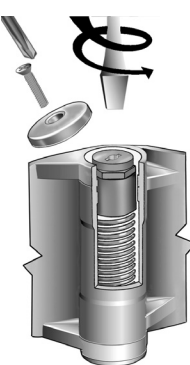

7. Open the gate sufficiently to allow installation of the screws for the side-fixing legs. Note there are four screws remaining for each hinge. A pilot hole of ⁵/₃₂" (4mm) will be required.

8. **Adjust tension:** Remove the endcap at the "adjustable" end of the hinge. Use the large slot-head screwdriver to depress and turn the internal spring-loaded adjuster counter-clockwise. Hold the desired tension and allow to rise back into retention sleeve. Replace endcap.

The gate is now ready for use. Ensure the gate cannot swing beyond 180° through the line of the fence by installing a latch or 'gate stop'.

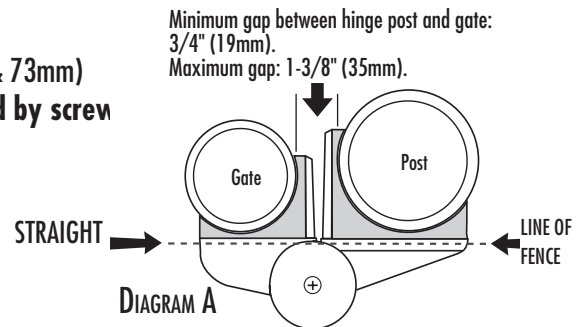

DIAGRAM A
FLUSH-MOUNTED LATCHES
 Maintain 180° alignment during installation to ensure accurate, reliable closure.

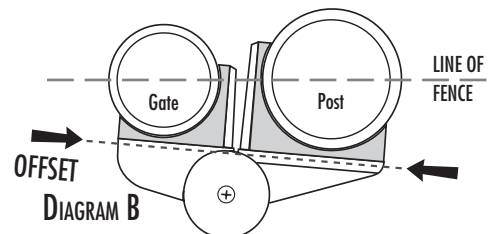
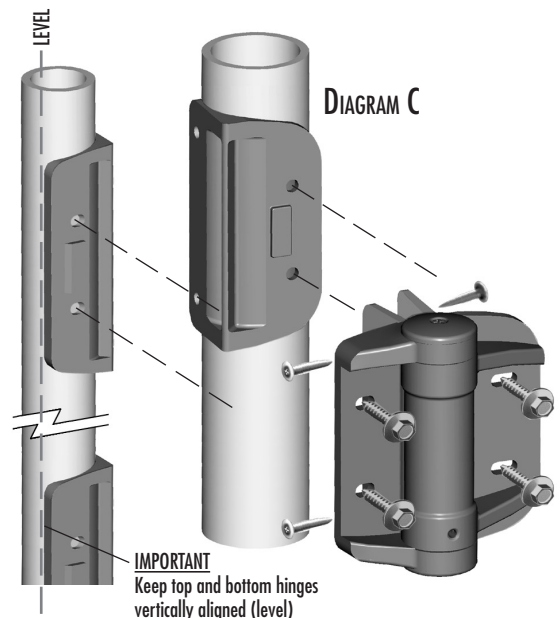

DIAGRAM B
CENTER-MOUNTED LATCHES
 The hinge can be offset slightly to help align the latch in the middle of the latch post.



D&D Technologies
 Hi-Performance Hardware

AUSTRALIA: Unit 6, 4-6 Aquatic Dr, Frenchs Forest NSW 2086

USA: 7731 Woodwind Drive, Huntington Beach, CA 92647

www.ddtechglobal.com

MAINTENANCE & REQUIREMENTS:

- Always use two ROUND-POST HINGES on any one gate.
- Ensure the gate does not swing beyond 180°.
- Each hinge must have equal tension at all times.
- Remove all other types of hinges and self-closing devices.
- Do not lubricate these hinges with petroleum-based lubricants. Use only powdered graphite.
- Never remove ROUND-POST HINGES from gate until spring tension is released.
- Do not physically alter hinge bodies by cutting, milling, machining or grinding any part.
- For safety, remove protruding bolts/screws after installation by cutting, grinding and/or filing.

For a downloadable Adobe Acrobat (.PDF) version of our Limited LIFETIME WARRANTY, go to our website at www.ddtechglobal.com

TCHDRND1000PA

•INSTR-TCHDRND1_1 11 11